

SMART Board™ Interactive Whiteboard

Specifications – Model V280

Physical Specifications

Size	64" W x 53 1/8" H x 4" D (162.4 cm x 134.9 cm x 10.1 cm)
Active Screen Area (maximum interactive, projected image)	61 3/8" W x 46 1/8" H (155.9 cm x 117.2 cm) 76 7/8" diagonal (195.2 cm)
Weight	30 lb. (13.6 kg)
Shipping Weight	
1 unit	70 lb. (31.8 kg)
8 units on pallet	585 lb. (265.4 kg)
Shipping Size	
1 unit	58 7/8" W x 74" H x 6 5/8" D (149.5 cm x 188 cm x 16.8 cm)
8 units on pallet	58 7/8" W x 78 1/2" H x 52 7/8" D (149.5 cm x 199.4 cm x 134.4 cm)

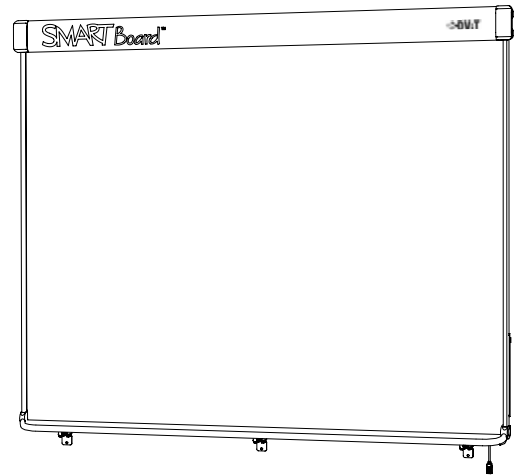

All dimensions +/- 1/8" (3.2 mm). All weights +/- 2 lb. (0.9 kg).

Standard Features

Software	SMART Board™ software, including SMART Notebook software. Software upgrades are available at www.smarttech.com/support/software/index.asp .
Pen Tray	A simple, robust pen tray spans the width of the interactive whiteboard.
Pens	Two pens, each powered by one AAA battery
Resolution	Touch resolution is approximately 4096 x 4096.
Screen Surface	The hard laminate surface is puncture resistant and optimized for projection.
Digitizing Technology	DViT™ (Digital Vision Touch) technology uses two digital cameras to track the infrared pen tip across the display surface.
Frame Finish	Graphite gray frame and pen tray (approximates Pantone® 425 C) and Ultrasonic Chrome valance (approximates metallic Pantone 877 C)
Wall-Mount Bracket	32" (81.3 cm) wide with five screws and drywall anchors to support a wall-mounted interactive whiteboard
Computer Connection	High-speed connection via a 16' (5 m) USB 2.0 cable
Power Requirements	The computer provides power directly through the USB cable for Windows® computers. Power consumption is less than 2.5 W (500 mA at 5V).
Security	Three Kensington® security slots
Certifications and Compliance	CSA (U.S./Canada), CB, CE, RoHS (China), RoHS (Europe), WEEE
Warranty	Five-year limited equipment warranty upon registration. See warranty document for details.

NOTE: A projector is not included with this SMART Board interactive whiteboard model. To take advantage of all interactive features, you must integrate a projector.

SMART Board Software Computer Requirements

Windows® Computers Intel® Pentium® 3, 1.2 GHz processor or faster
512 MB of RAM (1 GB recommended)
180 MB of free hard disk space for minimum installation
(840 MB for full installation with Gallery collections)
High speed, USB 2.0 compliant interface
Driver update for USB smart card reader (requires an Internet connection to access the [Microsoft® Update Catalog](#))
Windows XP operating system Service Pack 2 (SP2) or later
Updated USB Video Class (UVC) driver for Windows XP SP2 (recommended).
See Microsoft Corporation [document 899271](#).
Internet Explorer® Internet browser 6.0 or later
Adobe® Flash® player version 8

Disclaimer: The user acknowledges and accepts that the processing power of the computer stated above is required when the SMART Board V280 interactive whiteboard is used with a standard projector. The user further acknowledges and accepts that in the event that accessories are added to the computer (including but not limited to the AirLiner™ slate, the Senteo™ interactive response system and/or the SMART Document Camera), the user will be required to increase the processing power of the computer substantially. SMART will not be held responsible or liable for any damage caused or loss suffered as a result of insufficient processing power.

Storage and Operating Specifications

Storage -40°F to 120°F (-40°C to 50°C)
Operation 41°F to 95°F (5°C to 35°C) with up to 80% humidity non-condensing

SMART Order Number

SBV280 77" (195.6 cm) diagonal SMART Board V280 interactive whiteboard

Replacement Parts and Optional Accessories

Part Number	Description
FRU-SB6WM	SMART Board interactive whiteboard wall mounting kit (includes five screws and five drywall anchors)
FSV280	Mobile floor stand for SMART Board V280 interactive whiteboards

Dimensions

Wall-Mounted
Cutaway View

Leave at least 5/8" (1.6 cm) headroom to wall mount the SBV280.

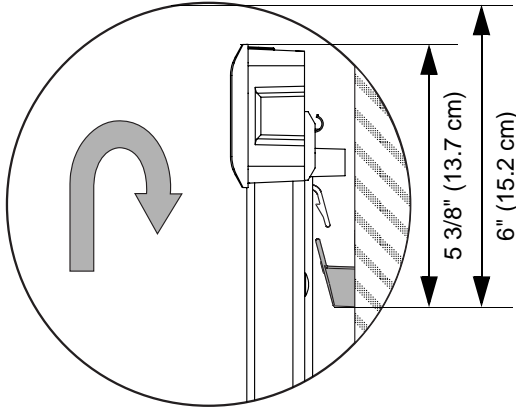

Wall-Mounted
Side View



Wall-Mounted
Front View

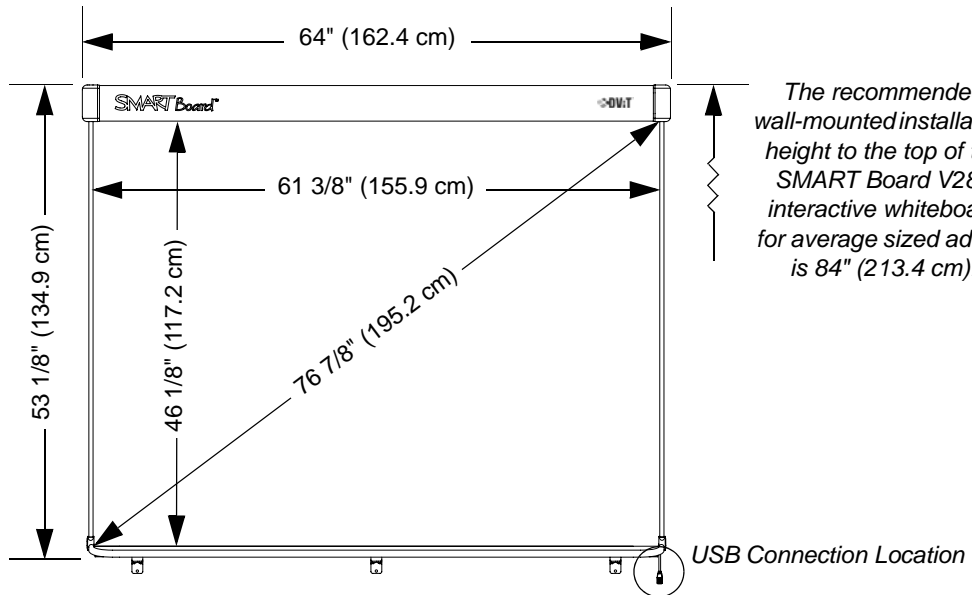

The recommended wall-mounted installation height to the top of the SMART Board V280 interactive whiteboard for average sized adults is 84" (213.4 cm).

All dimensions +/- 1/8" (3.2 mm)

www.smarttech.com/support www.smarttech.com/contactsupport
Support +1.403.228-5940 or Toll Free 1.866.518.6791 (U.S./Canada)

© 2008 SMART Technologies ULC. All rights reserved. The SMART logo, SMART Board, AirLiner, Senteo and smarttech are trademarks or registered trademarks of SMART Technologies ULC in the U.S. and/or other countries. All other third-party product and company names may be trademarks of their respective owners. Patent No. US5448263; US6141000; US6320597; US6326954; US6337681; US6741267; US6747636; US6803906; US6919880; US6947032; US6954197; US6972401; US7151533; US7184030; US7236162; CA2058219; CA2453873; CA2386094; and EP1297488. Other patents pending. Contents are subject to change without notice. 11/2008.

